

# OPERATING INSTRUCTIONS

# MODEL: BS/A USA and BS/A SC

## 1. PRODUCT IDENTIFICATION

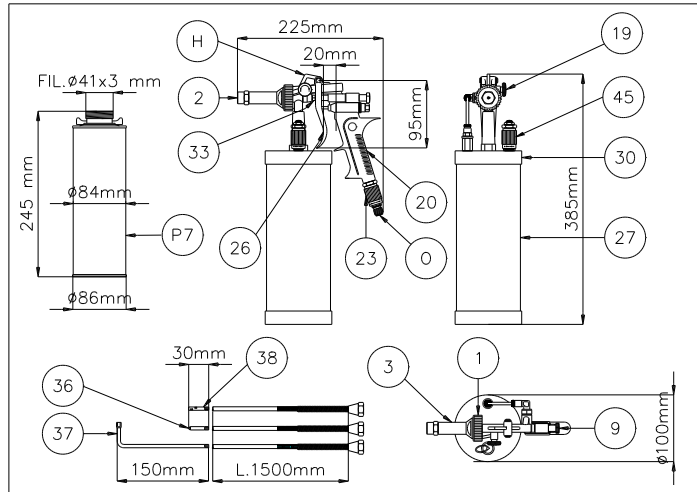

- 0. \_ Gas pneumatic supply
- 1. Ring – BS01
- 2. Sprayhead cap – BS02
- 3. Sprayhead – BS03
- 9. Product control knob – BS09
- 19. Air Control knob – BS19
- 20. Handgrip – BS20
- 23. Air regulator – BS23
- 26. Trigger – BS26
- 27. Tank - BS27
- 30. Tank cap – BS30
- 33. Adjustment nut– BS33
- 36. Mist wand – BS36
- 37. 90° Spray wand – BS37
- H. Hook

## 2. GENERAL WARNINGS

When selecting, and before using, the product to be sprayed with the gun, verify that it is in fact compatible with the work environment and the individual safety devices employed, according to the product safety sheet.

Never point the spray gun at yourself, other people or animals, or in any case at anything else other than the object to be treated.

While operating the spray gun, wear the appropriate safety garments and devices (gloves, goggles, masks, overalls, etc.) according to the instructions listed in the product safety sheet. The use of goggles is always recommended.

Hang the gun on the special hook when it is not being used so as to guarantee its vertical position. Never tilt the spray gun at an angle greater than 45° either while operating or when not in use, in order to avoid fouling of the spray gun ducts.

## 3. GETTING STARTED

Connect the gun to a compressed air supply. We recommend the use of an in-line filter/reducer to ensure a clean air supply.

- ° Approximate air consumption of the spray gun: 200-300 liters per minute (55-80 gallons per minute)
- ° Working pressure: 3-4 BAR (45-60 psi)
- ° Maximum working pressure: 10 BAR (150 psi)
- ° Recommended length of supply hose: 10 meters (30 feet)
- ° Minimum interior diameter of air hose: 6mm (1/4 inch)
- ° Air supply connection: male \_ gas
- ° Product can be packaged in standard US Quart cans or poured directly into the tank

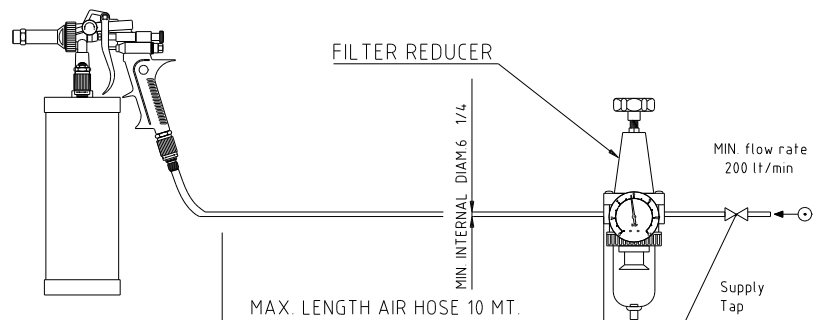

#### 4. SPRAYING SOLVENT BASED PRODUCTS

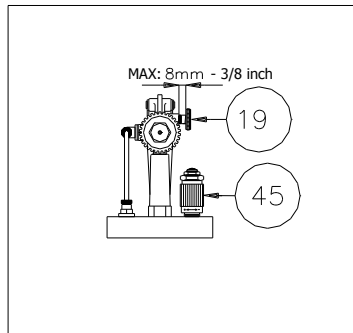
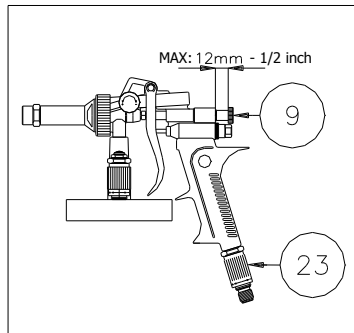

Turning the product control knob (BS09) clockwise will gradually reduce the rate of product flow. Turning it counter-clockwise will increase the product flow.

Air flow can be controlled by the air regulator (BS23). **IMPORTANT:** Turn clockwise to increase the air flow, turn counter clockwise to decrease the air flow.

Turn the air control knob (BS19) clockwise to close the air passage gradually. This will reduce the atomization and make the texture rougher. Turn the air control knob counter-clockwise to increase atomization and spray a smoother texture.

Combinations: Even rougher and smoother textures can be obtained by adjusting knobs BS19 and BS09 in combination.

- ° Less product (BS09 clockwise) and more atomization (BS19 anti-clockwise) gives a smoother finish
- ° More product (BS09 counter-clockwise) and less atomization (BS19 clockwise) will produce a more textured finish.

#### 5. SPRAYING RUSTPROOFING WAX

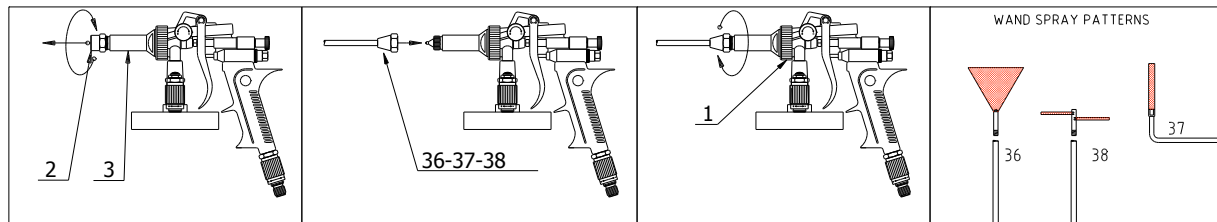

The gun is supplied with wands to spray wax based rustproofing. The wax can be sprayed directly out of the gun or with the wands attached.

To attach the spray wands, remove the spray cap head (BS02) and screw the appropriate wand on the exposed thread of the spray head (BS03). Use spray wands, BS36, BS37 or BS38 for wax based products only. If you need a wand for an undercoating or sound proofing product, order wand BS39 (not shown).

#### 6. CLEANING

**Solvent based products:** The gun is hermetically sealed which allows the product to stay in the tank, without drying out, for a period of one month. We recommend a periodic cleaning depending on the usage of the gun.

To clean, simply fill a clean and empty can with solvent and spray. Follow federal and local Hazmat regulations and collect used solvent for proper disposal. If no clean empty canister is available, the solvent can be poured directly into the tank. Always make sure the atomization knob (BS19) is completely closed. Some product might accumulate on the spray cap head (BS02). This can usually be

removed with ones' fingernail. Unscrew the tank and clean the product intake tube and inside the tank, do not immerse the spray gun completely into solvent but clean with brush or cloth.

**Wax based products:** Wax based products sprayed without the wand should be cleaned as in previous description. When using wands, end the application by purging the leftover product from the wand, by pulling the trigger half way. This is usually enough to clean the wand for future use. When a buildup is noticed, purge the leftover product and spray solvent through the wand.

## 7. DANGER

- ° Follow product manufacturer's warnings for spraying flammable and/or dangerous products. Do not smoke and never spray in vicinity of open flames. Make sure air control knob (BS19) is closed when spraying cleaning solvent. Atomized vapors are extremely flammable.
- ° Do not exceed the maximum extension for the product control knob (BS09) and the air control knob (BS19) when gun is under pressure.
- ° Always disconnect gun from air supply before filling, repair work or cleaning is preformed.

## 8. TROUBLESHOOTING

PROBLEM:	CAUSE:	CORRECTIVE ACTION:
gun does not spray when trigger is pulled	no air supply	Open air control knob (BS19) Open air regulator located at handgrip (BS23) Check air hose, filter, reducer and compressor.
gun only sprays air when trigger is pulled	no product supply	Open product control knob (BS09)
uneven spraying	Irregular product supply	Clean all ducts and spraying nozzles Do not tilt spray gun at an angle greater than 45°
uneven spraying	Irregular air supply	Check on air filter Check hose for condensation
product leaking at needle packing	worn/loose packing	Slightly tighten the adjustment nut (BS33) Replace packing (BS32)

## 9. MAINTENANCE

- ° Whenever necessary lubricate needle in area before the adjustment nut (BS33).
- ° Check gasket (BS29) on inside of the tank cap, replace if necessary.

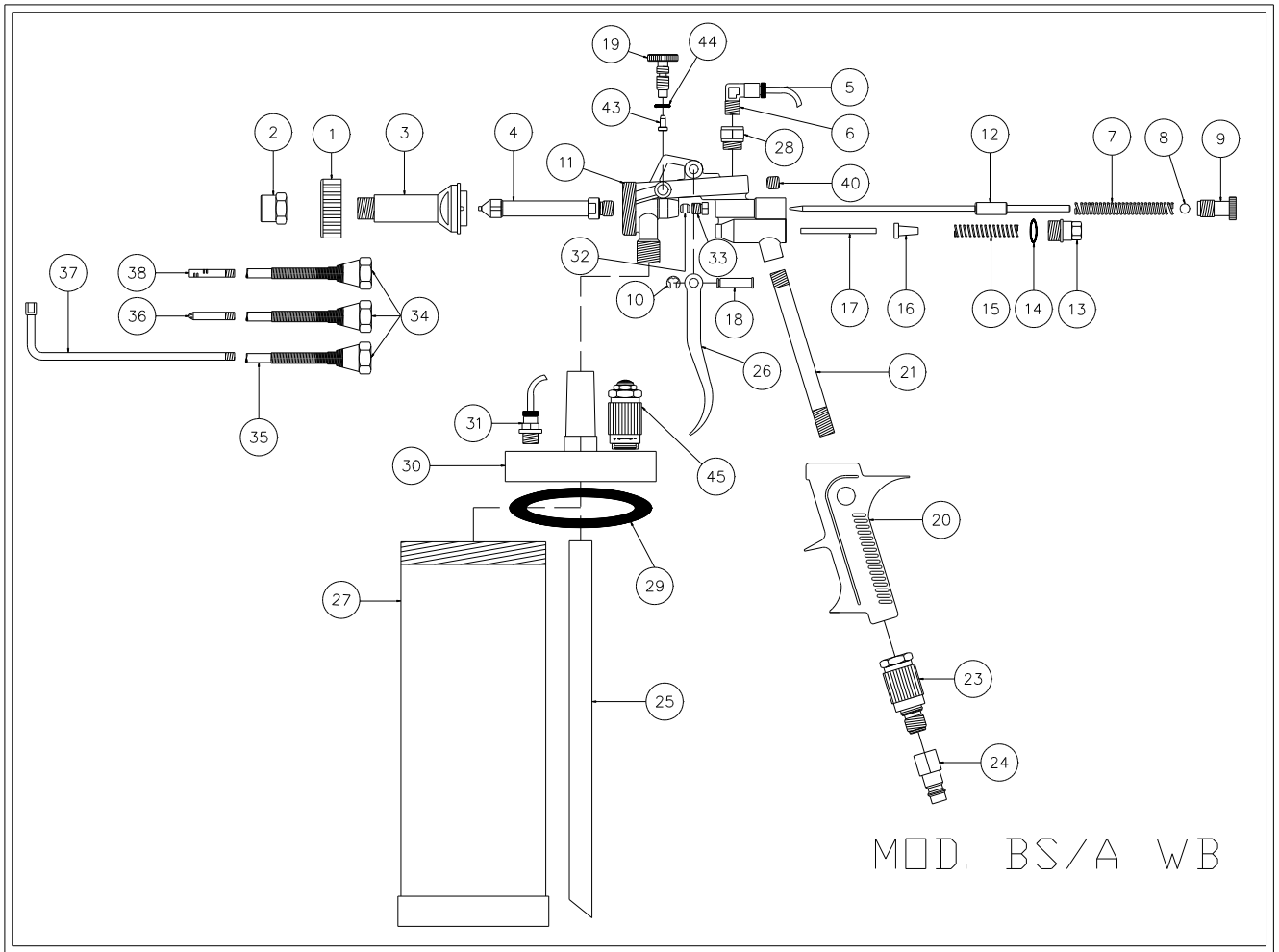

DRAWING NUMBER	DESCRIPTION	PRODUCT NUMBER	DRAWING NUMBER	DESCRIPTION	PRODUCT NUMBER
1	RING	BS01	20	HANDGRIP BLACK	BS20
2	SPRAYHEAD CAP	BS02	21	AIR SUPPLY TUBE	BS21
3	SPRAYHEAD	BS03	23	AIR REGULATOR	BS23
4	NOZZLE W/ EXTENSION	BS04	24	AIR HOSE CONNECTOR	BS24
5	AIRLINE	BS05	25	PRODUCT INTAKE TUBE	BS25
6	COUPLING (L-SHAPED)	BS06	26	TRIGGER	BS26
7	SPRING (needle)	BS07	27	TANK (black)	BS27
8	BEARING	BS08	28	BASE NUT (L-shaped coupling)	BS28
9	PRODUCT CONTROL KNOB	BS09	29	GASKET	BS29
10	LOCKING WASHER	BS10	30	TANK CAP (black)	BS30
11	GUN BODY	BS11	31	COUPLING (straight)	BS31
12	NEEDLE	BS12	32	NEEDLE PACKING	BS32
13	STOP SCREW	BS13	33	ADJUSTMENT NUT	BS33
14	GASKET	BS14	34-35	Not Available Separately	
15	SPRING (trigger)	BS15	36	MIST WAND COMPLETE	BS36
16	PACKING	BS16	37	90° SPRAY WAND COMPLETE	BS37
17	SPINDLE (trigger)	BS17	39	UNDERCOATING WAND (not pictured)	BS39
18	TRIGGER PIN	BS18	40	ALLEN SCREW	BS40
19	AIR CONTROL KNOB	BS19			